

VERSION 1

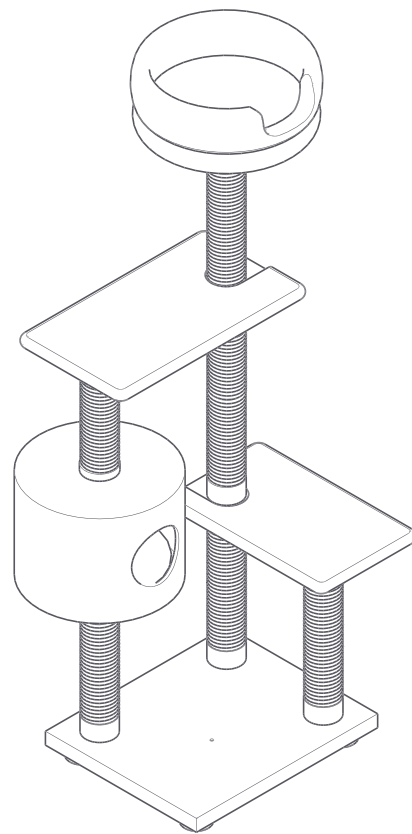

VERSION 2

AUFBAU | ASSEMBLY | MONTAGE

DE Der Aufbau muß von Erwachsenen durchgeführt werden, nach dem Zusammenbau ist eine Endkontrolle durchzuführen! Nach ca. 14 Tagen sollen die Schrauben nachgezogen werden.

AT

CH

IE Adult assembly is required; check before use! Retighten the screws after ca. 14 days.

GB

FR L'assemblage doit être assuré par un adulte. Vérifier avant l'emploi. Après environ 14 jours revisser.

NL Montage dient te gebeuren door volwassenen; controleren voor gebruik. Na ca. 14 dagen moeten de schroeven nogmaals aangedraaid worden.

HU A felépítést felnőtteknek kell végrehajtania, az összeszerelés után végső ellenőrzést kell végezni! Kb. 14 nap múlva a csavarokat után kell húzni.

IT Adulti requesti per controllo dell'assemblaggio. Controllare prima dell'uso. Dopo ca. 14 giorni si prega di riavvitare i bulloni.

DK Skal opstilles af en voksen. Efter samling skal der gennemføres en slutkontrol! Efter ca. 14 dage skal skruerne spændes efter.

Montaż winna przeprowadzać osoba dorosła, po złożeniu należy przeprowadzić weryfikację! Po upływie ok. Dwa tygodni należy dokręcić śruby.

ca. B 74 x T 63 x H 175 CM

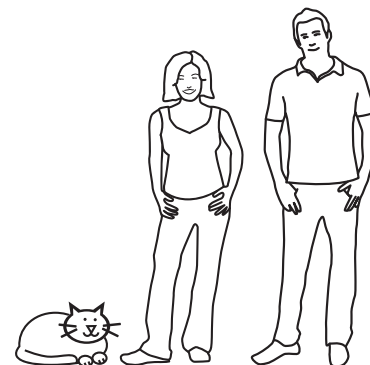

VERSION 1

4 x S1

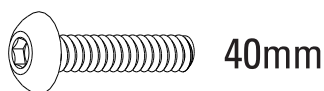

40mm

2 x S5

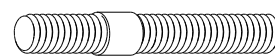

3 x S2

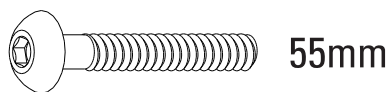

55mm

5 x S6

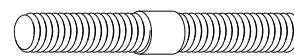

3 x S3

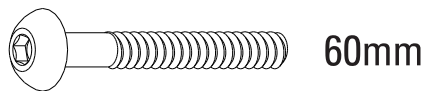

60mm

4 x S7



1 x S4

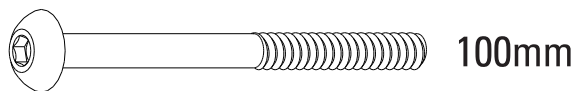

100mm

5 x S8

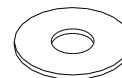

Ax1

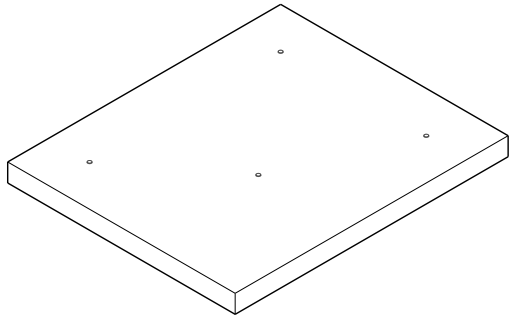

Bx1

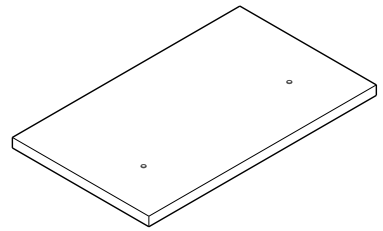

Cx1

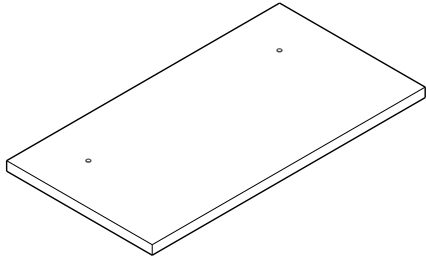

Dx1

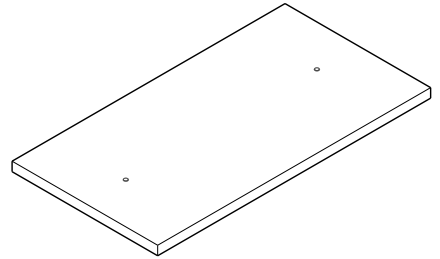

Ex1

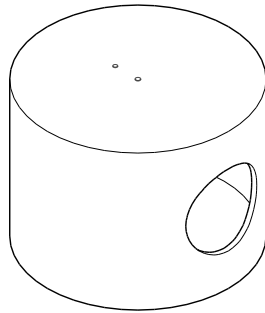

Fx1

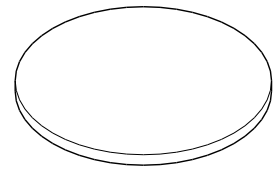

Gx3

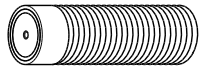

Hx6

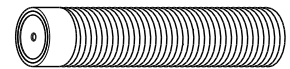

Ix1

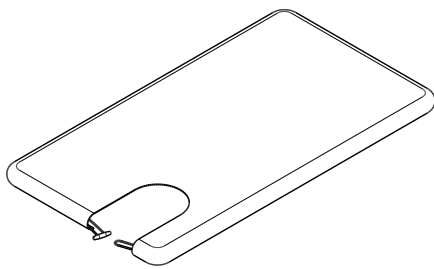

Jx1

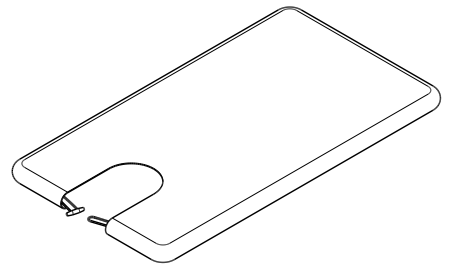

Kx1

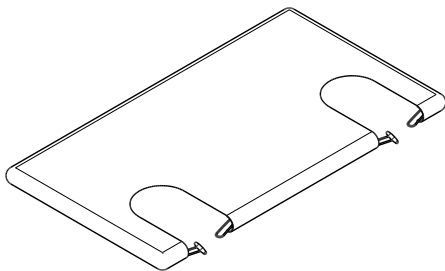

Lx1

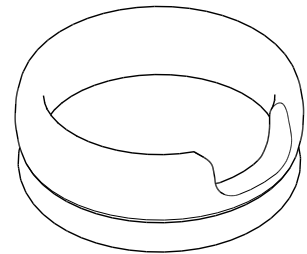

Mx1

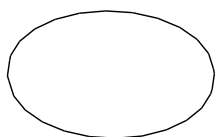

Nx4



Ox2



1

4 x S1

4 x S7

A x 1

N x 4

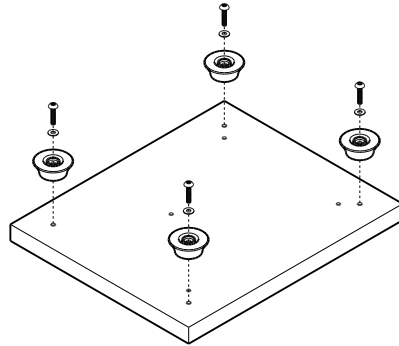

2

3 x S3

3 x S8

H x 3

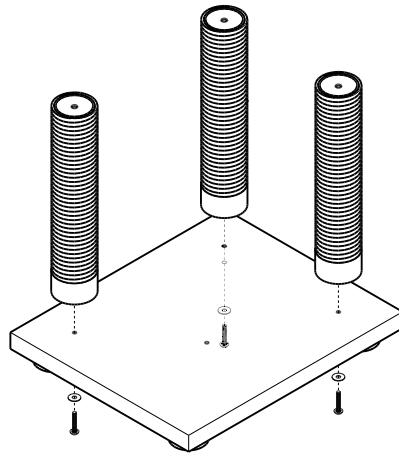

3

1 x S2

1 x S8

E x 1

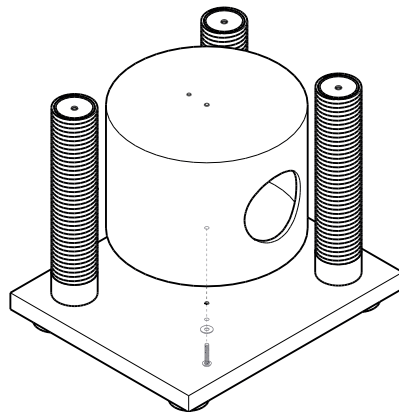

4

1 x S2

2 x S6

B x1

G x2

O x1

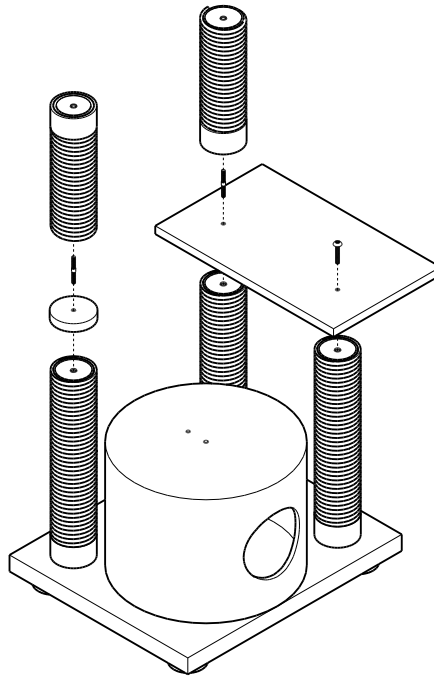

5

1 x S5

C x1

H x1

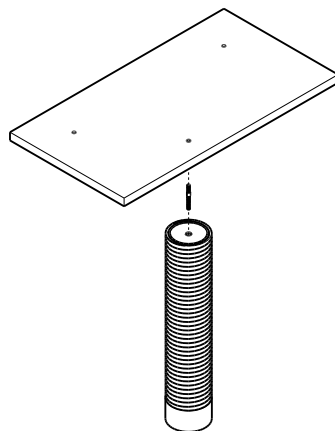

6

1 x S4

1 x S8

2 x S6

H x 2

0 x 1

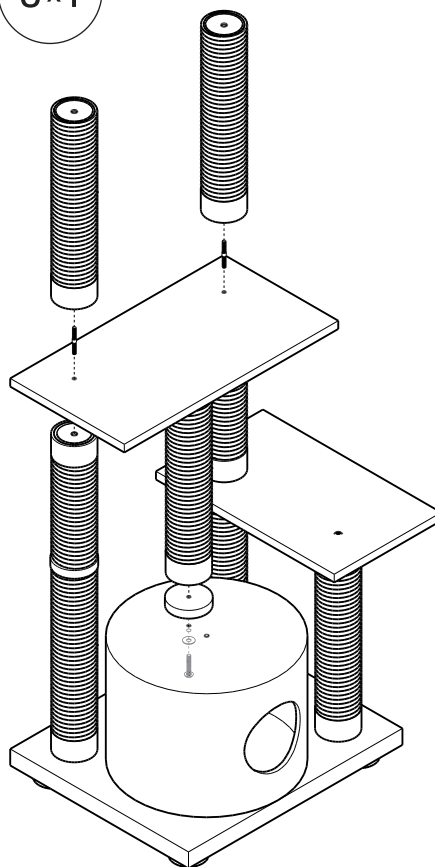

7

1 x S2

1 x S6

D x 1

G x 1

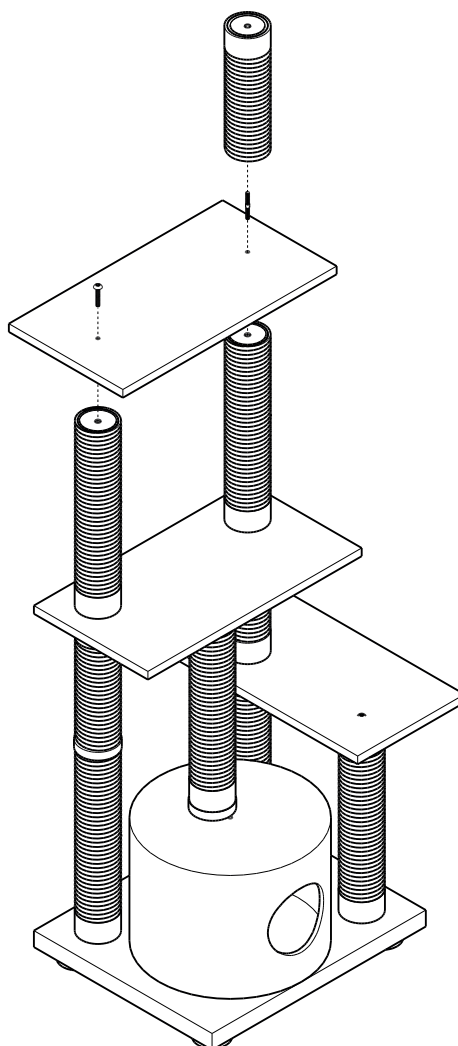

8

1 x S5

Fx1

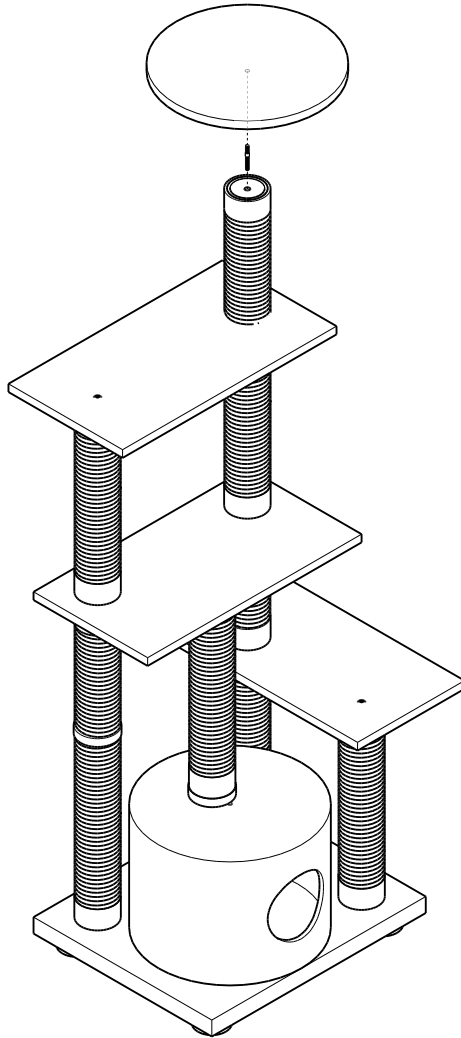

9

Ix1

Jx1

Kx1

Lx1

Mx1

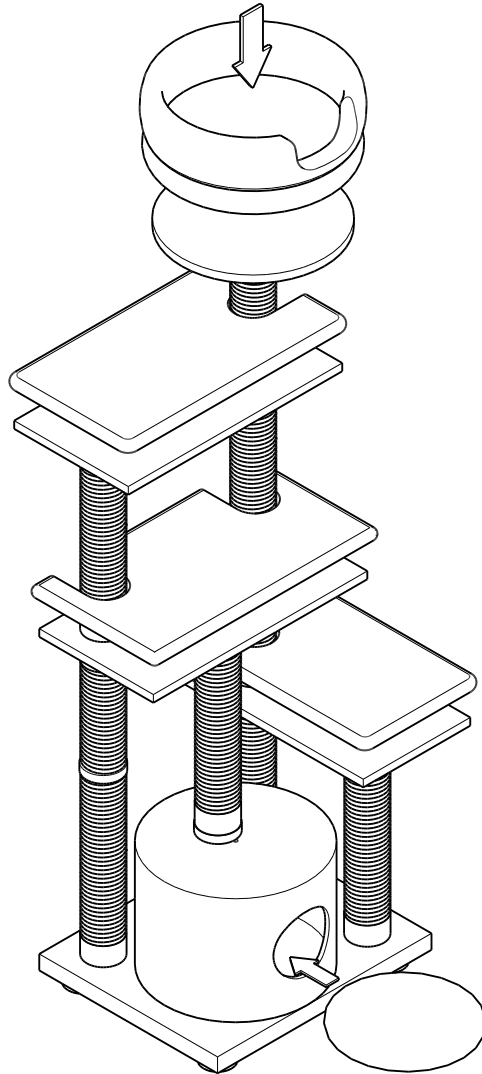

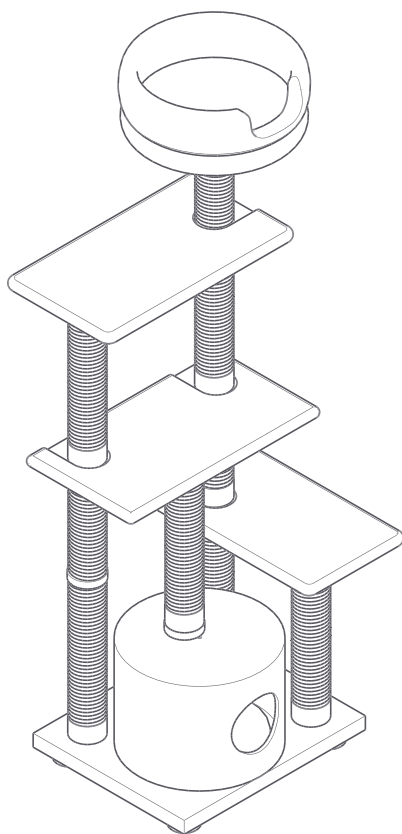

VERSION 1

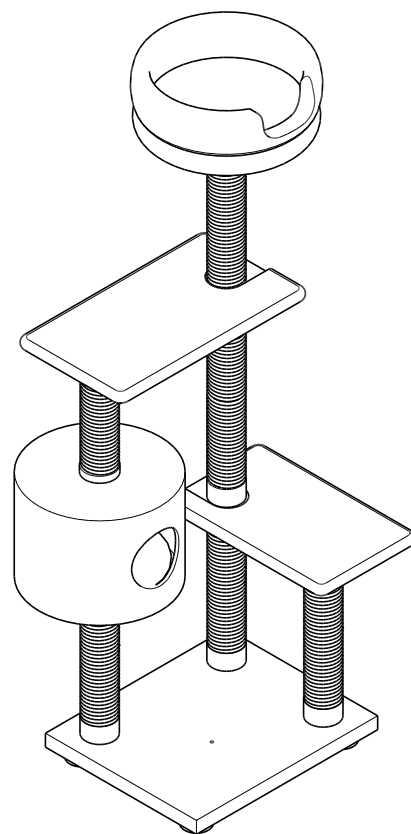

VERSION 2

AUFBAU | ASSEMBLY | MONTAGE

DE Der Aufbau muß von Erwachsenen durchgeführt werden, nach dem Zusammenbau ist eine Endkontrolle durchzuführen! Nach ca. 14 Tagen sollen die Schrauben nachgezogen werden.

AT

CH

IE Adult assembly is required; check before use! Retighten the screws after ca. 14 days.

GB

FR L'assemblage doit être assuré par un adulte. Vérifier avant l'emploi. Après environ 14 jours revisser.

NL Montage dient te gebeuren door volwassenen; controleren voor gebruik. Na ca. 14 dagen moeten de schroeven nogmaals aangedraaid worden.

HU A felépítést felnőtteknek kell végrehajtania, az összeszerelés után végső ellenőrzést kell végezni! Kb. 14 nap múlva a csavarokat után kell húzni.

IT Adulti requesti per controllo dell'assemblaggio. Controllare prima dell'uso. Dopo ca. 14 giorni si prega di riavvitare i bulloni.

DK Skal opstilles af en voksen. Efter samling skal der gennemføres en slutkontrol! Efter ca. 14 dage skal skruerne spændes efter.

Montaż winna przeprowadzać osoba dorosła, po złożeniu należy przeprowadzić weryfikację! Po upływie ok. Dwoch tygodni należy dokręcić śruby.

ca. B 83 x T 63 x H 175 CM

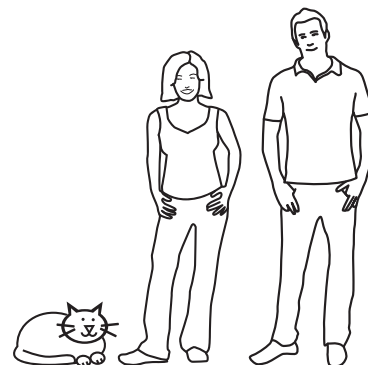

VERSION 2

4 x S1

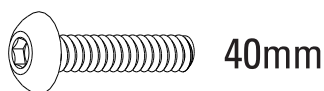

2 x S5

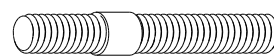

2 x S2

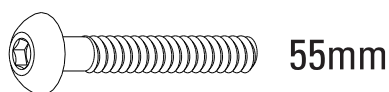

3 x S6



3 x S3

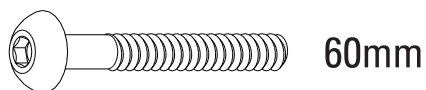

4 x S7



1 x S4

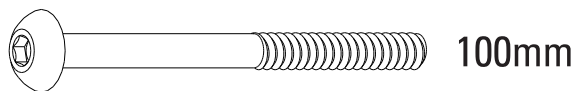

4 x S8

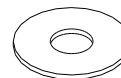

Ax1

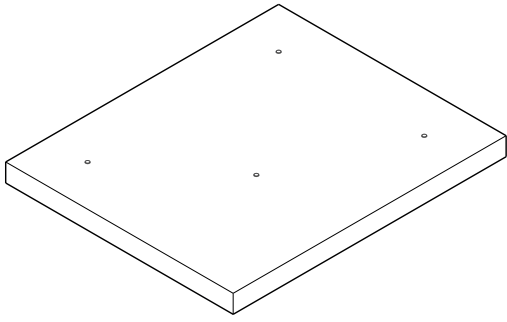

Bx1

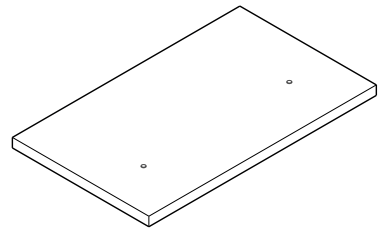

Cx1

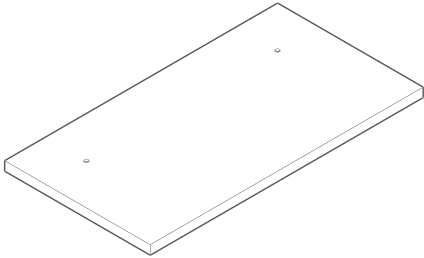

Dx1

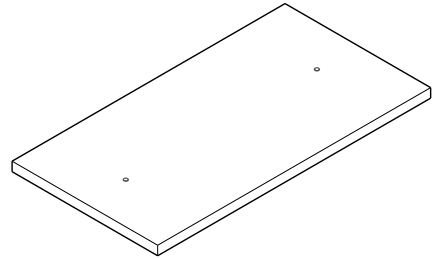

Ex1

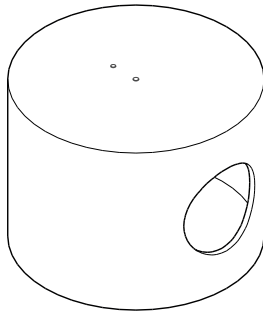

Fx1

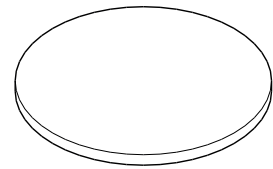

Gx3

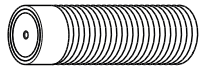

Hx4

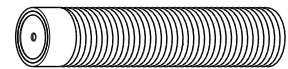

Ix1

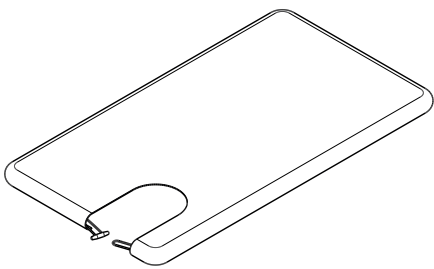

Jx1

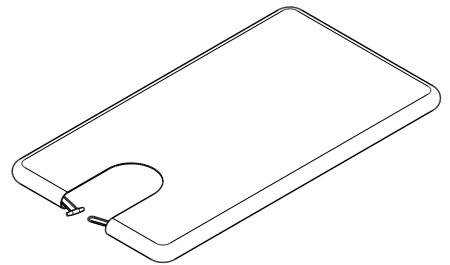

Kx1

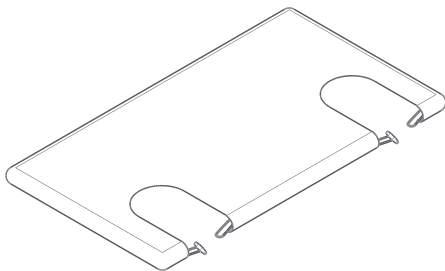

Lx1

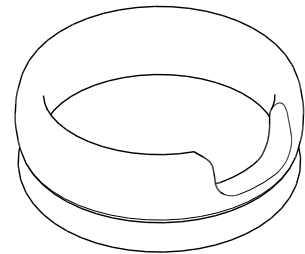

Mx1

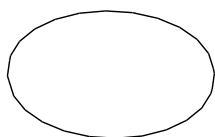

Nx4



Ox1



1

4 x S1

4 x S7

A x 1

N x 4

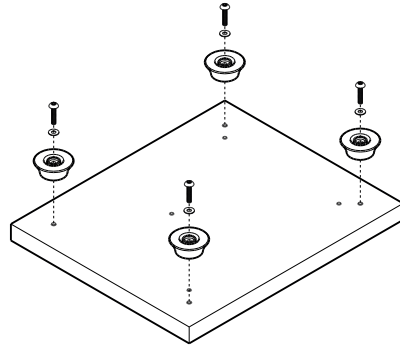

2

3 x S3

3 x S8

H x 3

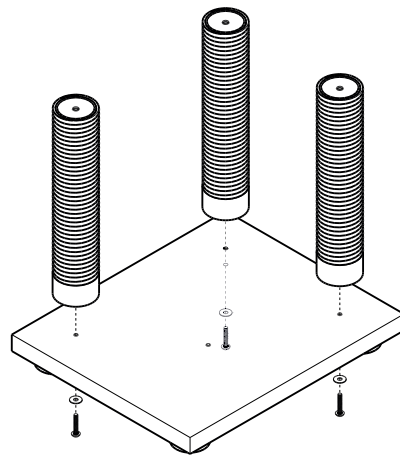

3

1 x S2

1 x S6

B x 1

G x 1

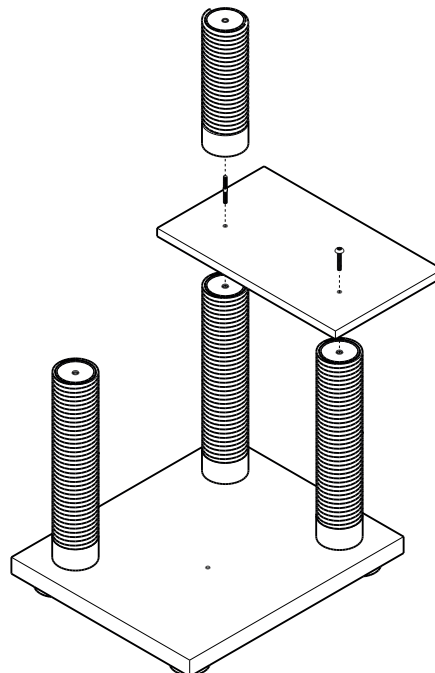

4

1 x S5

E x 1

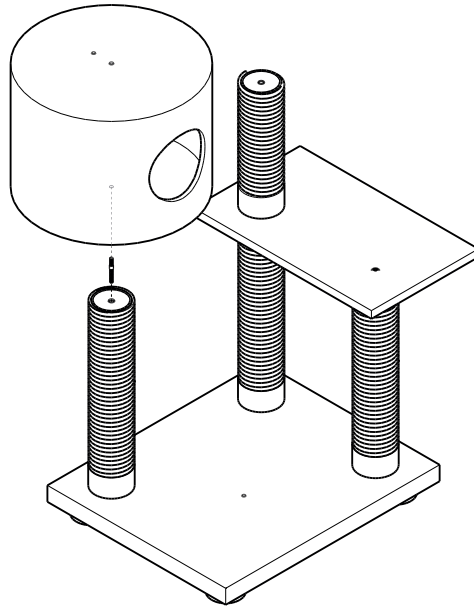

5

1 x S4

1 x S6

1 x S8

G x 2

0 x 1

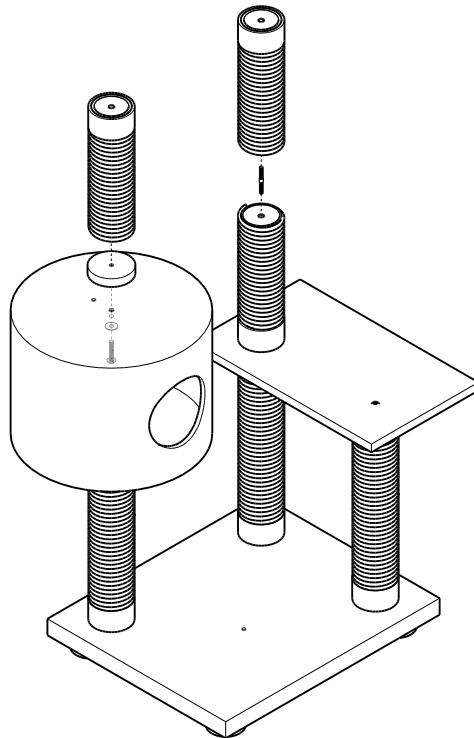

6

1 x S2

1 x S6

D x 1

H x 1

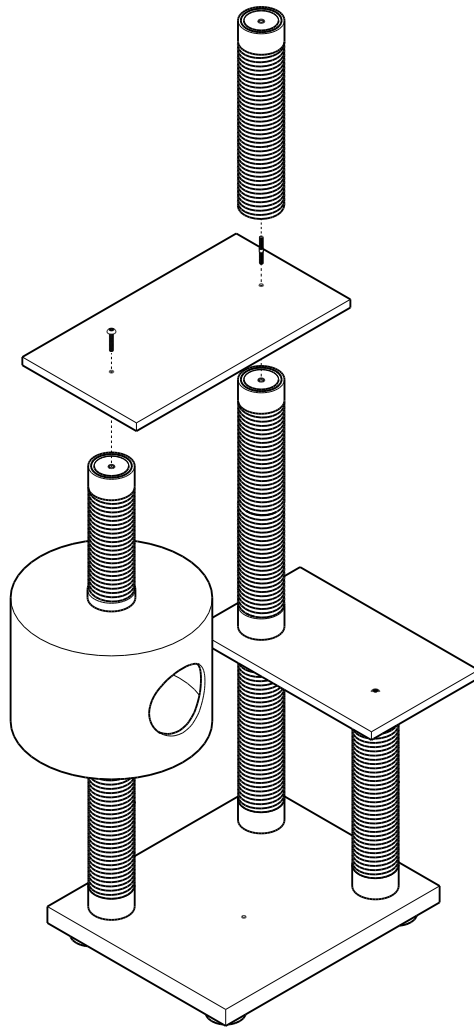

7

1 x S5

Fx1

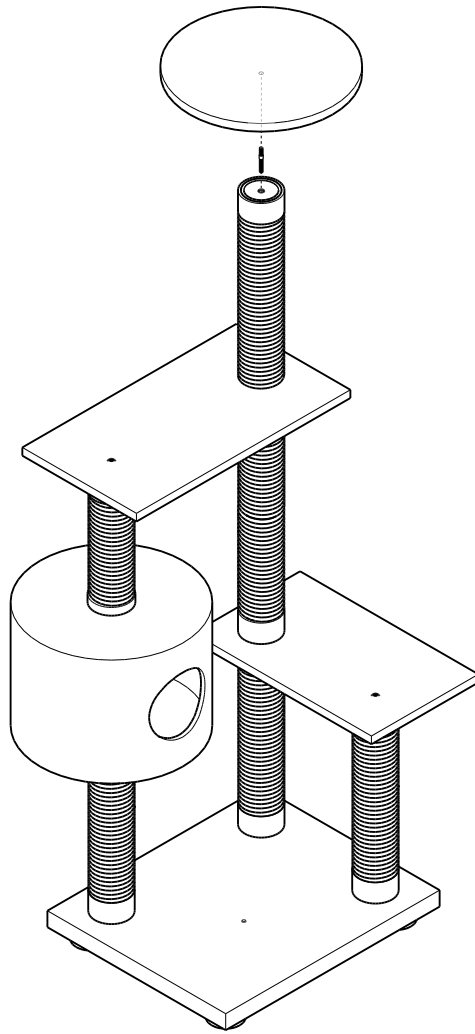

8

Ix1

Jx1

Lx1

Mx1

